



# PA SDI-Drives Midi™ PA SDI-Drives Maxi™

---

## SDI Interface Manual

Edition 07.44

**Type of documentation** Project planning

**Intention of the document** This document gives information about

- Installation
- Hardware

**Previously published editions:**

<b>Edition</b>	<b>Comment</b>
07.44	First Edition

**Protective note** All rights reserved. No part of this work may be reproduced in any form (by printing, photocopying, microfilm or any other method) or stored, processed, copied or distributed by electronic means, without the written permission of Power Automation

**Remark** Technical changes to improve the performance of the equipment may be made without prior notice!

**Publisher** Power Automation GmbH  
Gottlieb-Daimler-Strasse 17/2  
D-74385 Pleidelsheim  
Phone: +49 (0) 7144-899-0  
Fax: +49 (0) 7144-899-299

<b>0.</b>	<b>Contents</b>	
<b>1.</b>	<b>GENERAL</b>	<b>4</b>
1.1	Description .....	4
1.2	Standards .....	4
<b>2.</b>	<b>INSTALLATION / SETUP</b>	<b>5</b>
2.2	LED Processing .....	5
2.3	Safe Restart Lock (only SDI/RL – Interface) .....	6
2.3.1	Implementation .....	6
2.3.2	Principle of Operation .....	7
2.3.3	Additional Safety Notes .....	8
2.3.4	Functional Test .....	9
2.3.5	Simple Connection Example using Contact Switches .....	10
2.3.6	Example using Safety PLC .....	11
<b>3.</b>	<b>HARDWARE</b>	<b>12</b>
3.1	Technical Data .....	12
3.2	Pinning .....	13
3.3	Address switch .....	14
3.4	Analog inputs .....	14
3.4.1	Four independent inputs .....	14
3.4.2	Two differential inputs .....	15

## 1. GENERAL

### 1.1 Description

The SDI – Interface is mounted in the PA SDI-Drives Midi™ / Maxi™. It enables the full functionality of the drive.

It is connected to a controller via a special synchronous serial high speed connection

- Full setup of the parameters, actual values, commands and scope function
- Real time communication every 1ms to 8ms
- Firmware download

Two hardware versions are available. One with “Safe Restart Lock” – function (SDI/RL – Interface and one without the safety function SDI – Interface

- 4 digital inputs with capture functionality (position latch)
- 4 x +/- 10V analog inputs (resolution 12Bit), either 4 channel single ended or 2 channel differential)
- “Safe restart lock” with ENABLE input, LOCK input, EN-BRAKE input and safe condition relay output “SAFE LOCK” (only for SDI/RL – Interface)

### 1.2 Standards

Safety standards

- EN 60204 Safety of machinery – Electrical equipment of machines
- EN ISO 13849 Safety of machinery – Safety-related parts of control systems
- EN 954-1 Safety of machinery – Safety-related parts of control systems

[Back to Contents](#)

## 2. INSTALLATION / SETUP

### 2.2 LED Processing

The SDI – Interface and the SDI/RL – Interface have two LEDs, a red and a green, that display the actual communication state.

<b>Green LED</b>	<b>State</b>
Off	No bus communication at all
On	Bus communication available

<b>Red LED</b>	<b>State</b>
Off	No drive related bus communication
On	Drive related bus communication available

[Back to Contents](#)

## 2.3 Safe Restart Lock (only SDI/RL – Interface)

PA SDI-Drives Midi™ / Maxi™ in combination with the SDI/RL – Interface, supports the safety function “safe restart lock” according to the requirements of the control category of EN 954 Part 1 and Part 2 category 3 and ISO 13849 performance level “d”.

For this purpose, the drive has two independent safety paths in parallel connection.

The safety category is reached, when the signal “SAFE LOCK” is additionally verified.

In addition to that, also the holding brake is part of the circuitry. The control category of EN 954 Part 1 and Part 2 category 1 and ISO 13849 performance level “c” is reached for the electrical circuitry of the holding brake processing. If the holding brake supply input +24V-BR has an additional circuitry; the safety category can be increased.

### 2.3.1 Implementation

The following block diagram gives an overview over the internal circuitry.

The signals LOCK and ENABLE are directly connected to the microcontroller and also to two independent switch-off delayed circuitries, which delay the signals in hardware for about 0.5sec.

The delayed LOCK – signal switches off the power supply of the driver for the IGBT-powerstage. The delayed ENABLE – signal switches off the control signals to the power stage, so two independent signals switch off the power stage in different ways.

The signal EN-BRAKE is also galvanic isolated from the internal electronic potential by opto coupler and is connected to a switch-off delayed circuitry, which delays the signal in hardware for about 0.5sec. The undelayed signal is connected to the microcontroller and the delayed signal switches off the 24V power supply of the holding brakes.

The effect of the three signals is supervised and only if all signals are in the safe state, the relay “SAFE LOCK” closes the contact between S1 and S2.

If one or all of the signals ENABLE, LOCK or EN-BRAKE are switched off in emergency stop condition, the drive decelerates the motors (stop category 1 according to EN 60204-1).

If all three signals are switched off, the drive is brought into the safe restart lock condition after the delay time of 0.5sec.

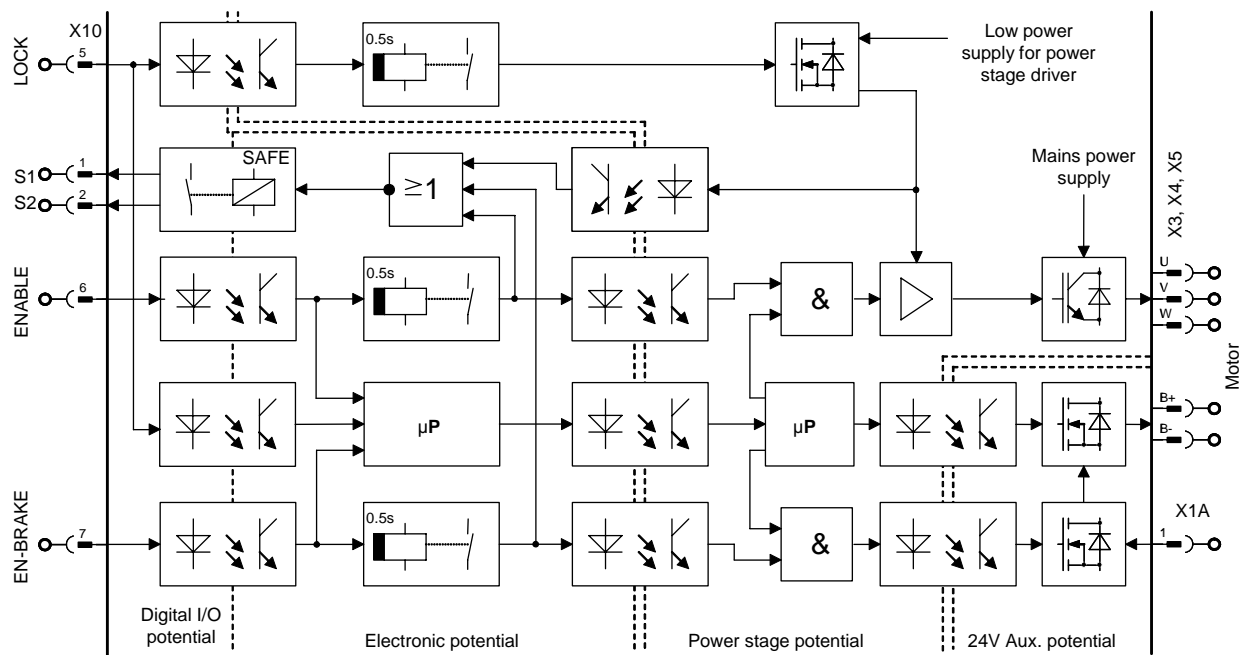

Block diagram of the safe restart lock circuitry

[Back to Contents](#)

### 2.3.2 Principle of Operation

The function “safe restart lock” uses three digital inputs, to bring the drive in this state.

- ENABLE – input
- LOCK – input
- EN-BRAKE – input

All three signals have to be open or low, to enable the “safe restart lock” function. To simplify the external emergency stop circuitry in the cabinet, the three inputs disable the drive directly via microcontroller. The microcontroller decelerates the motor to zero speed and disables the power stage. In parallel, the three inputs are switched-off delayed by hardware for about 0.5sec. After this time, the inputs force the drive in the safe state.

- The ENABLE – input inhibits the control signals of the power stage.
- The LOCK – input switches off the supply voltage of the drivers of the IGBT power stage. This is the second path to switch off the control signals of the power stage.
- The EN-BRAKE – input switches the 24V supply of the holding brake off. This input can be set to high to release the holding brake for manual move of the mechanics (in combination with **K-BRAKE** = 1) without losing the safe restart lock of the power stage. Even if no holding brake is connected to one or more of the axes, the enable input has to be set to “high” to be able to enable the drives.

The state of the supply voltage (on/off) of the drivers is fed back and combined in or – logic with the internal ENABLE signal and the internal EN-BRAKE signal.

Only if the three signals are in the safe state, the “SAFE LOCK” relay contact of output S1/S2 is closed and symbolises the state “safe restart lock” after about 0.6 sec.

When the inputs LOCK, ENABLE and EN-BRAKE are switched to high, the drive is not enabled directly. In addition to that, a software enable (**K-EN** = 1 or the corresponding bit in the control word) has to be set to enable the power stage.

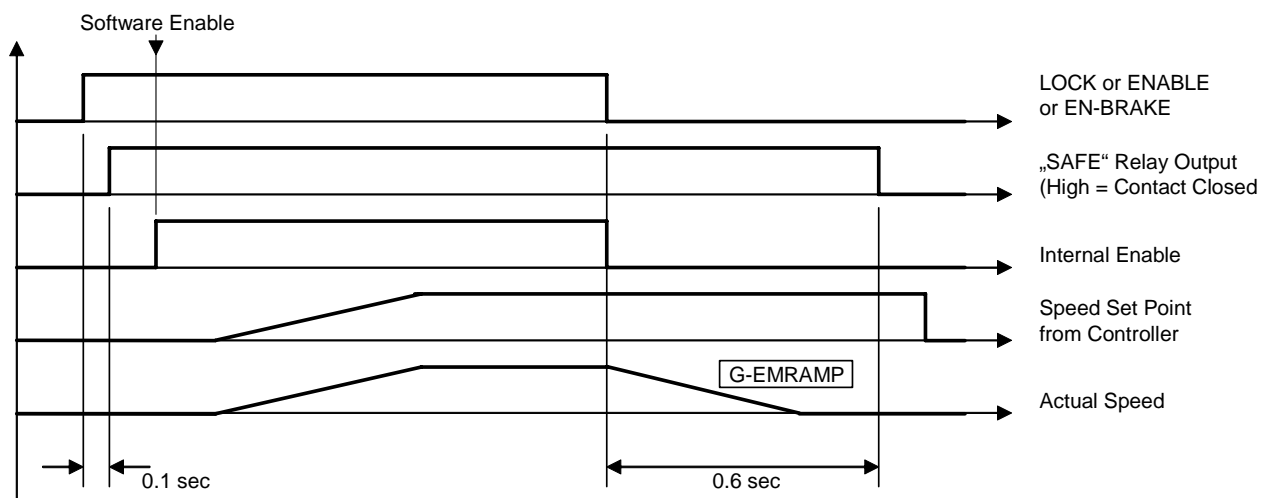

[Back to Contents](#)

### 2.3.3 Additional Safety Notes



- Only qualified personnel are permitted to install and set up the “safe restart lock” function
- All control components (switches, relays, PLC, etc.) and the control cabinet must comply with the requirements of the EN 954-1, EN 954-2 and ISO 13849. This includes:
  - Door – switches, etc. with protection class IP54 as minimum
  - Control cabinet with protection class IP54 as minimum
- Use insulated wire end sleeves
- Control cable length of the inputs ENABLE, LOCK, EN-BRAKE and output “SAFE LOCK” is limited to 25 m max.
- All safety-relevant cables (e. g. control cable for the safety relay, feedback contact) has to be installed e. g. in a cable duct, if pass outside the control cabinet. Make sure, that short circuits between single cables are excluded! For further measures see EN 954-2, table D4
- When an external force is likely to act with the function “safe restart lock” (e.g. force to the load by hanging load) additional measures have to be provided (e.g. double-disc spring set brake, instead of permanent magnetic-excited brake)

**Failure to observe this precaution can result in severe injury and equipment damage.**



The mains power supply of the drive has to be switched off by e.g. a mains contactor in case of:

- cleaning, maintenance and repair operations
- long down time periods

**Failure to follow any one of these instructions will result in death, serious injury or equipment damage.**

[Back to Contents](#)

### 2.3.4 Functional Test

The functional test of the safe restart lock is necessary, to check the correct mode of operation. This procedure has to be done:

- after installation
- on a regular basis, after one year at the latest



When the function check leads to impermissible states, check for errors and then restart the commissioning of the machine. If the function test has been unsuccessful, don't start the machine.

**Failure to observe this precautions can result in severe injury.**

#### Test specification

- Check the complete safety relevant circuitry for operational reliability
- Check the function of the "Safe Restart Lock" circuitry directly at the terminals of the S1300 using the state table below.

LOCK	State of the Inputs		Nor-signal of all Inputs	State of Output "SAFE LOCK"	Description
	ENABLE	EN-BRAKE			
Low	Low	Low	High	Contact closed after 0.6 sec	<b>Safe state for motor and holding brake</b>
High	Low	Low	Low	Contact open	Unsafe state
Low	High	Low	Low	Contact open	Unsafe state
High	High	Low	Low	Contact open	Unsafe state
Low	Low	High	Low	Contact open	Safe state for motor, manually operation of holding brake possible with <b>K-BRAKE</b> = 1
High	Low	High	Low	Contact open	Unsafe state
Low	High	High	Low	Contact open	Unsafe state
High	High	High	Low	Contact opens after 0.1 sec of High/Low transition of the NOR-signal	<b>Normal operation</b>

[Back to Contents](#)

### 2.3.5 Simple Connection Example using Contact Switches

In order to reach the control category of EN 954 Part 1, Part 2 category 3 and ISO 13849 performance level “d”, the signal “SAFE LOCK” (S1 and S2) must be additionally verified. This requires external wiring. The external wiring must be adapted to the existing safety concepts and checked for a reliable operation.

The holding brake circuitry reaches EN 954 Part 1, Part 2 category 1 and for the electrical circuitry ISO 13849 performance level “c”.

This circuit shows the minimum external wiring of the axis module, with switching contact for a motor with brake.

The ENABLE and EN-BRAKE signals are switched by the same switch. In this case, the axis cannot be moved manually. If this function is needed, an additional switch for EN-BRAKE is needed.

The function of this circuit is: The safe restart lock is activated, when the lamp is on. In this case, only the visual feedback is used.

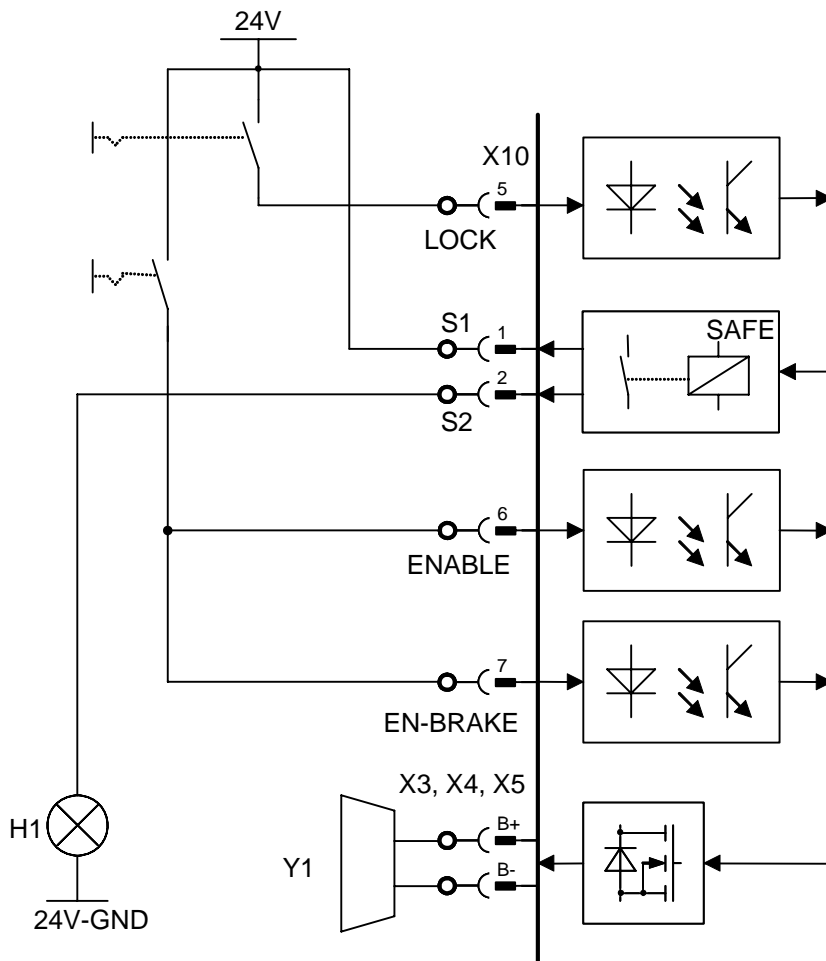

[Back to Contents](#)

### 2.3.6 Example using Safety PLC

In order to reach the control category of EN 954 Part 1, Part 2 category 3 and ISO 13849 performance level “d”, the signal “SAFE LOCK” must be additionally verified. This requires external wiring. The external wiring must be adapted to the existing safety concepts and checked for the correct operation.

The holding brake circuitry reaches EN 954 Part 1, Part 2 category 1 and ISO 13849 performance level “c” for the electrical circuitry.

The Safety-PLC must have two (or three) safe outputs and one safe input to bring the S1300 into the safe state. One side of the “SAFE LOCK” relay contact (S1/S2) is connected to 24V and the other to the PLC Input 1.

I/O at interface board	Separate manual holding brake operation	Holding brake controlled only in operation mode
LOCK	PLC Output 1	PLC Output 1
ENABLE	PLC Output 2	PLC Output 2
EN-BRAKE	PLC Output 3	PLC Output 2
“SAFE LOCK”	PLC Input 1	PLC Input1

The PLC must be programmed to meet the following requirements:

- The output and the input states are checked for plausibility according to the following table
- If an impermissible state is detected, the entire system is put into a safe state
- If the state of the inputs has changed from high to low, the contact of the “SAFE LOCK” relay closes by about 0.6 sec delayed. If the state of the inputs has changed from low to high, the contact of the “SAFE LOCK” relay opens by about 0.1 sec delayed.

State of the Inputs			Nor-signal of all Inputs	State of Output “SAFE LOCK”	Description
LOCK	ENABLE	EN-BRAKE			
Low	Low	Low	High	Contact closed after 0.6 sec	<b>Safe state for motor and holding brake</b>
High	Low	Low	Low	Contact open	Unsafe state
Low	High	Low	Low	Contact open	Unsafe state
High	High	Low	Low	Contact open	Unsafe state
Low	Low	High	Low	Contact open	Safe state for motor, manually operation of holding brake possible with <b>K-BRAKE = 1</b>
High	Low	High	Low	Contact open	Unsafe state
Low	High	High	Low	Contact open	Unsafe state
High	High	High	Low	Contact opens after 0.1 sec of Low/High transition of the NOR-signal	<b>Normal operation</b>

[Back to Contents](#)

### 3. HARDWARE

#### 3.1 Technical Data

	DIM	SDI – Interface / SDI/RL – Interface
<b>Outputs</b>		
Relay "SAFE LOCK", free Contact (NO), only for SDI/RL – Interface	V	DC max. 30, AC max 42
	A	Min. 10 $\mu$ , Max. 0.5
<b>Digital Inputs</b>		
Digital Inputs (LOCK, ENABLE, EN-BRAKE) only for SDI/RL – Interface	V <sub>dc</sub>	Low 0 ... 7 / high 12 ... 30
	mA	10 at 24V input voltage
Digital Inputs (IN1 to IN4)	V <sub>dc</sub>	Low 0 ... 7 / high 12 ... 30
	mA	10 at 24V input voltage
Start delay (IN1 to IN4)	$\mu$ s	Ca. 1
Switch off delay (IN1 to IN4)	$\mu$ s	Ca. 2
Jitter (IN1 to IN4)	$\mu$ s	$\pm$ 0,5
<b>Analog Inputs</b>		
Analog Inputs AIN1 to AIN4, resolution 12Bit (about 5mV per LSB)	V <sub>dc</sub>	+/- 10V
	Input resistance	42 kOhm
<b>Connections</b>		
Digital / Analog In-/Outputs (X10)	–	Mini-Combicon FMC 1,5 / 8 – ST – 3,5 (Spring-Cage Type)
<b>J1</b> SDI input from last participant	–	RJ45
<b>J2</b> SDI output to next participant	–	RJ45

[Back to Contents](#)

### 3.2 Pinning

Connector J1 is the SDI input connector from the controller / last drive and J2 the SDI output connector to the next drive.

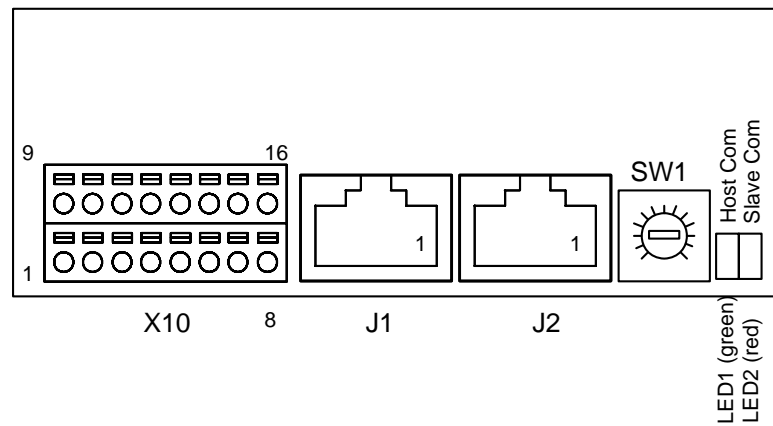

The pinning of the connectors is:

Connector X10	Pin	Function: digital In/Output
S1	1	Safety function relay "SAFE LOCK", free contact (NO)
S2	2	Safety function relay "SAFE LOCK", free contact (NO)
IN1	3	Digital Input 1
IN2	4	Digital Input 2
LOCK	5	Switch on of the driver supply of the power stage
ENABLE	6	Enables the power stage
EN-BRAKE	7	Enables the the holding brake supply
24V-GND	8	Ground for the digital inputs
IN3	9	Digital Input 3
IN4	10	Digital Input 4
AGND	11	Analog ground
AIN1	12	Analog input 1
AIN2	13	Analog input 2
AIN3	14	Analog input 3
AIN4	15	Analog input 4
AGND	16	Analog ground

**SW1** is the address switch for the bus address of the drive.

### 3.3 Address switch

The SDI bus system needs the setting of the slave address at the drives. Therefore the drive has an address switch SW1 (see [page 13](#)). Set the address by using a small screw driver at SW1.

[Back to Contents](#)

### 3.4 Analog inputs

The SDI – interface has four analog inputs. They can be used in two different modes, single ended or differential.

The selection of the two modes is done in the controller software.

#### 3.4.1 Four independent inputs

In this mode, four independent analog inputs are available.

Connect the analog signal to the input and the return (ground) to AGND (pin 11 or pin 16 of X10).

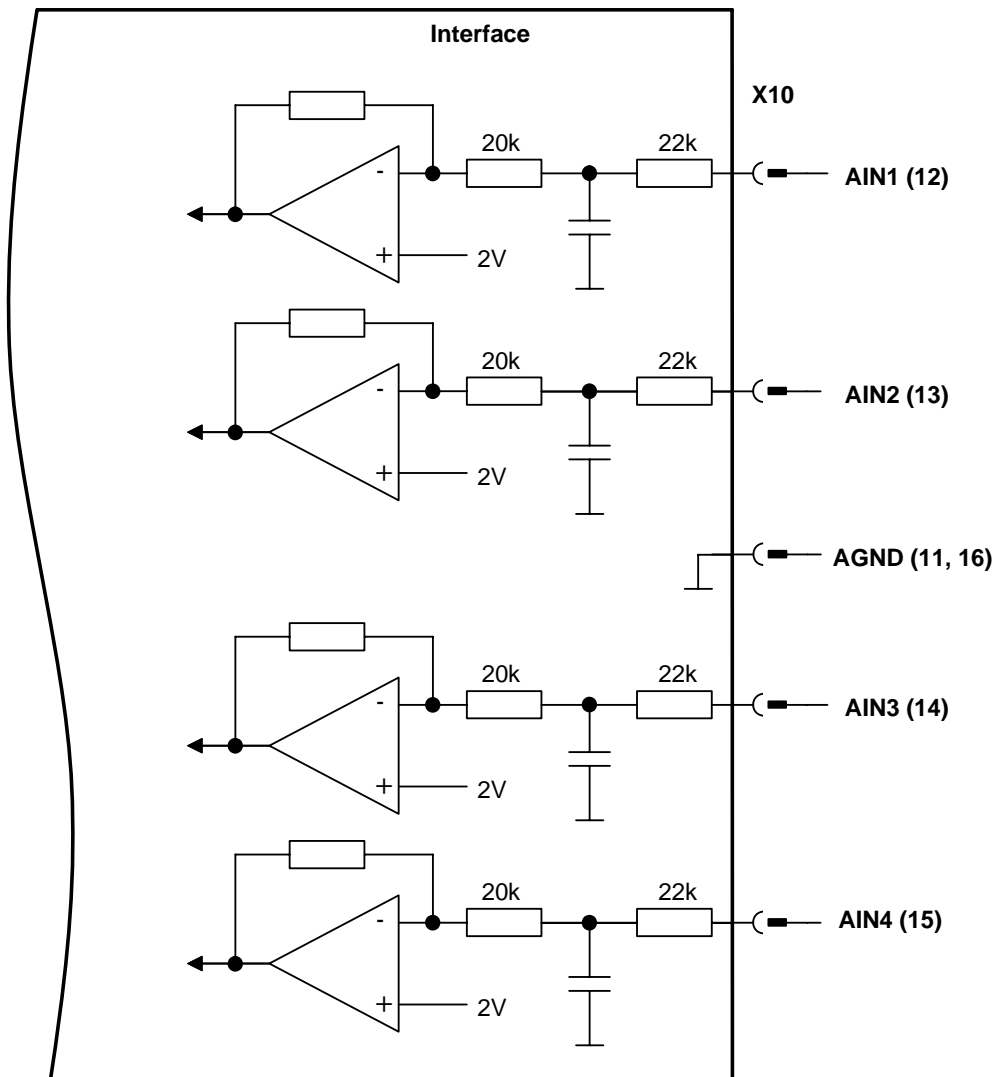

[Back to Contents](#)

### 3.4.2 Two differential inputs

The inputs AIN1 and AIN2 are used for one pair of inputs and AIN3 and AIN4 as the second pair. AIN1 and AIN3 are the inverted inputs and AIN2 and AIN4 are the non inverted inputs

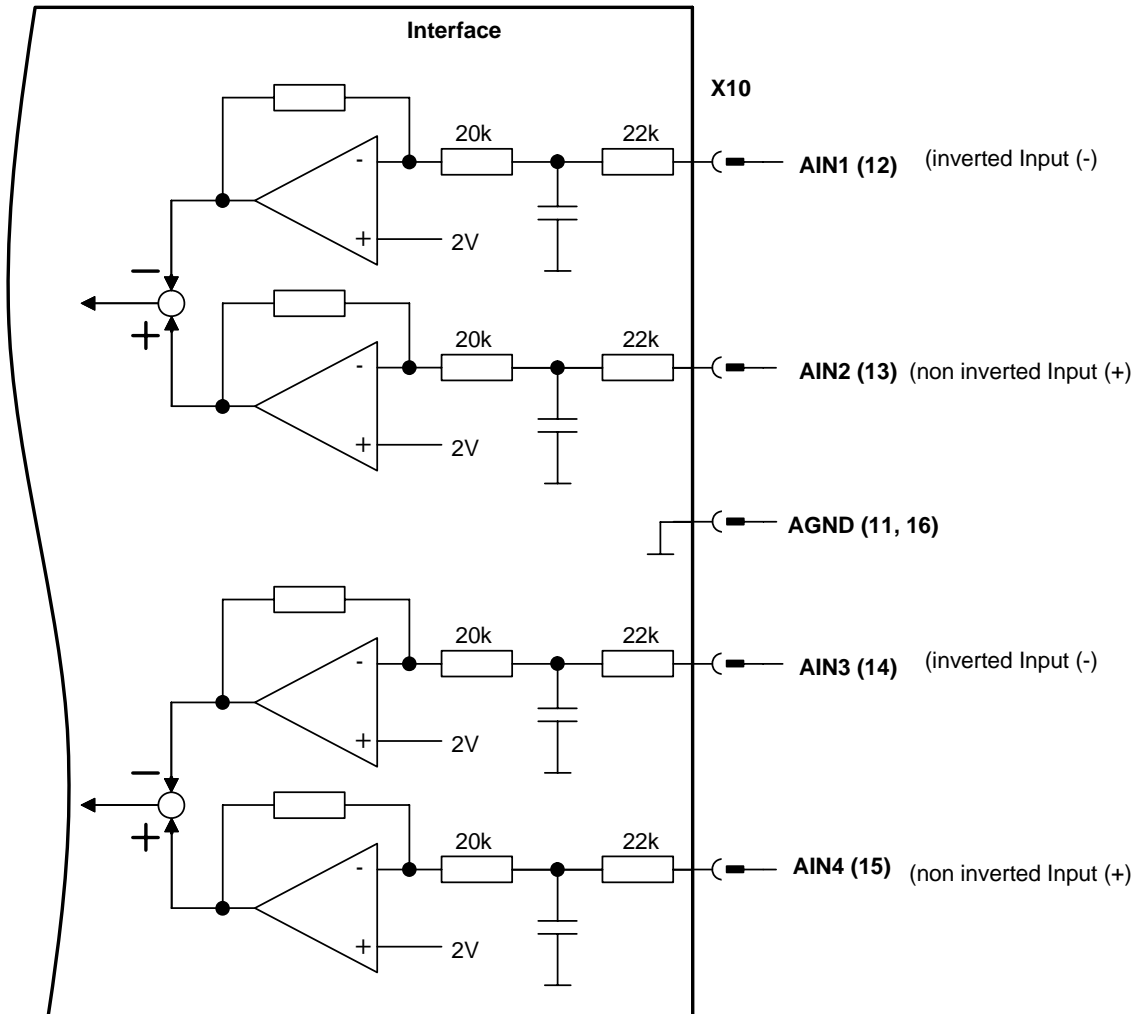

[Back to Contents](#)